



GRUNDFOS
ECADEMY

BASIC PRINCIPLES AND PUMP TYPES

CENTRIFUGAL PUMP TYPES

Centrifugal pumps

A pump is a device that raises or transfers fluid. Pumps come in many forms, but can generally be categorised according to two main operating principles: Positive displacement pumps and centrifugal pumps. This article deals exclusively with centrifugal pumps.

Centrifugal pumps serve many purposes:

- Circulation pumps are used to circulate water in closed systems that provide heat, air conditioning and hot water
- Pressure boosters increase the pressure of cold water in a system, and are used as condensate pumps for steam boilers
- Water supply pumps are normally used to supply water from wells, and come in above-ground and submersible versions
- Some centrifugal pumps are used exclusively for industrial purposes. These pumps include industrial pumps and wastewater pumps



The construction

In 1689 the physicist Denis Papin invented the centrifugal pump, and today centrifugal pumps are the world's most commonly used pumps. The centrifugal pump is built on a simple principle: Liquid goes through the impeller eye and is pushed outwards by means of a centrifugal force towards the periphery of the impeller. The construction is fairly inexpensive, robust and simple, and its high speed makes it possible to connect the pump directly to an asynchronous motor. The centrifugal pump provides a steady liquid flow, and it can easily be throttled without causing any damage to the pump.

Now let us have a look at **figure 1**, which shows the flow through the pump. The inlet of the pump leads the liquid to the centre of the rotating impeller, from where it is flung towards the periphery. This construction results in high efficiency and is suitable for handling pure liquids. Pumps that have to handle impure liquids, such as wastewater pumps, are fitted with an impeller that is specially constructed to prevent objects from getting stuck inside the pump. If a pressure difference occurs in the system while the centrifugal pump is not running, liquid can still pass through it due to its open design.

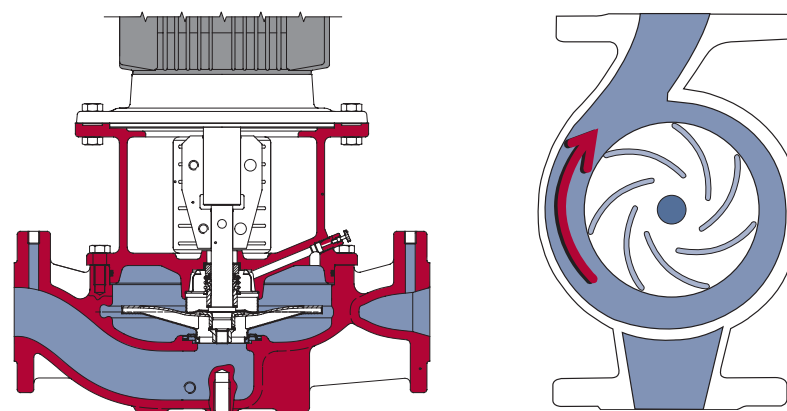

Fig. 1: The liquid's flow through the pump

Types of centrifugal pumps

As you can see from **figure 2**, centrifugal pumps can be categorised in different groups: **Radial flow pumps, mixed flow pumps and axial flow pumps. Radial flow pumps and mixed flow pumps are the most common types used.**

Different demands on a centrifugal pump's performance, especially with regard to head, flow, and installation, together with demands for economical operation, are only a few of the reasons why so many types of pump exist. **Figure 3** shows the different pump types with regard to flow and pressure.

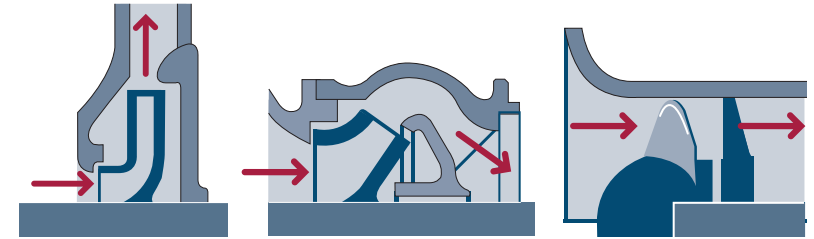

Fig. 2: Different kinds of centrifugal pumps

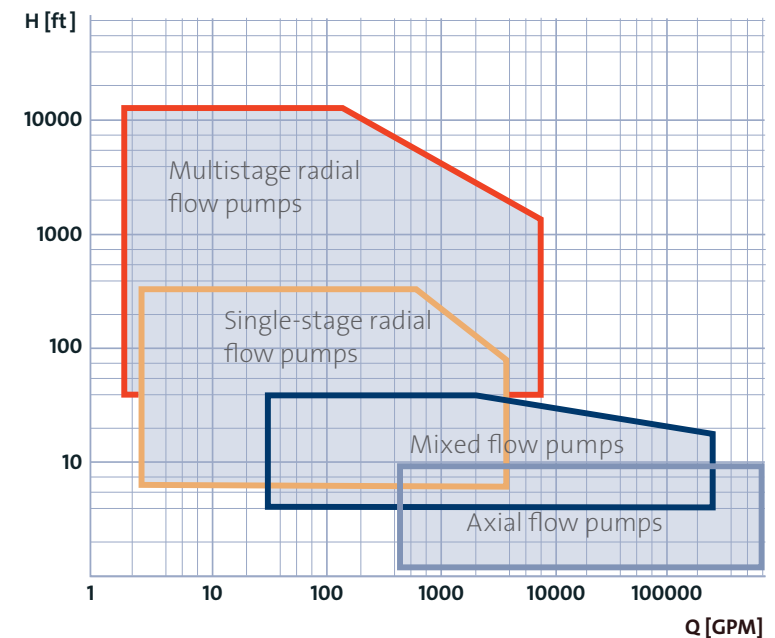

Fig. 3: Flow and head for different types of centrifugal pumps



GRUNDFOS ECADEMY

be
think
innovate

GRUNDFOS 